



FENWAL CONTROLS OF JAPAN, LTD.

Explosion-Proof Smoke Detector FLS-02EC-H2



Applications:

- Chemical plants
- Combustible storage facilities
- Battery rooms
- Engine rooms, etc. for indoor use



FLS-02EC-H2 is certificated with FM approval of Explosion-Proof Smoke Detector. **FLS-02EC-H2** detect smoke using the scattered light. There are a light emitter (Infrared LED) and a detector (photo-diode) in a chamber of **FLS-02EC-H2**. The Infrared LED emits the light through the lens, and the photo-diode detects the scattered light, which is reflected with smoke particles.



FENWAL CONTROLS OF JAPAN, LTD.

Electronic Specifications

Rating	DC24V, 5mA (Standby), 10mA(Alarm)
Range of the voltage	DC24V ± 10%
Alarm Level	1.8 to 3.1 %/ft
Status LED	Color: Red -Normal: Blinks once in 10 seconds -Alarm: Blinks once in 2 seconds -Trouble: Light out
Output Relay	Alarm Relay: Form A, DC24V 1A. Trouble Relay: Form B, DC24V 1A.
Temperature Range	Operating 0°C ~ +50°C Storage -20°C ~ +70°C
Humidity Range	30 to 85 %RH (No Condensation)

Mechanical Specifications

Dimensions	W136mm × D136mm × H100mm (See Figure 1)
Material	Aluminum alloy (ADC12)
Terminals	Wire: 0.2-2.5mm ² or AWG24-12 Terminal Board: See Figure2
Thread Options	M20 (Option: NPT1/2inch)
Weight	Approx. 2.0kg

Certifications

FM Certification	FM18US0151X Class1, Division1, Group B, C, D T6 Ta = 0°C to +50°C Class1, Zone1, AEx db IIB+H2 T6 Gb Ta = 0°C to +50°C
IECEX Certification	IECEX FMG 16.0040X Standards IEC60079-0: 2011 (Ed: 6.0) IEC60079-1: 2014-06 (Ed: 7.0) Ex db IIB+H2 T6 Gb
ATEX Certification	FM16ATEX0107X II 2G Ex db IIB+H2 T6 0°C ≤ Ta ≤ +50°C



IECEX Certification Standards



ATEX Certification



Dimensions

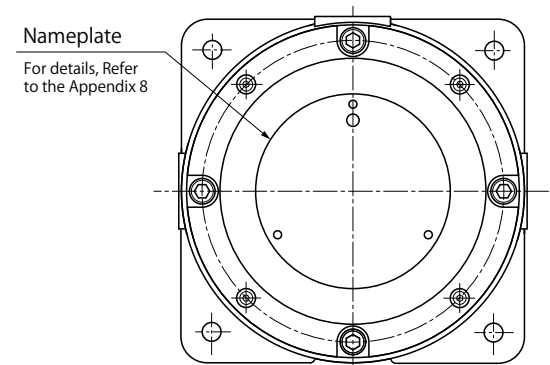
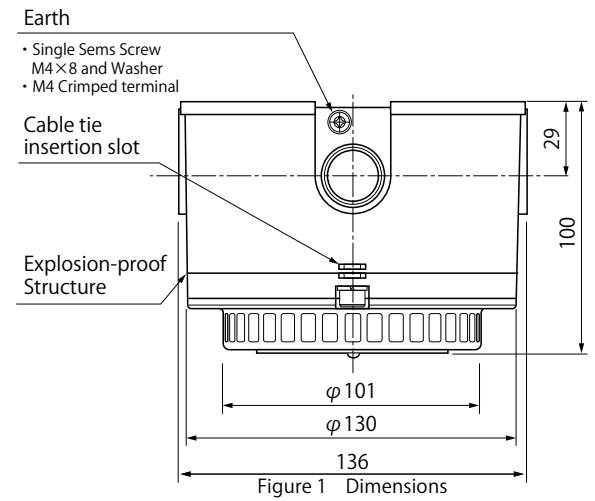

Pin assignments of Terminal Board

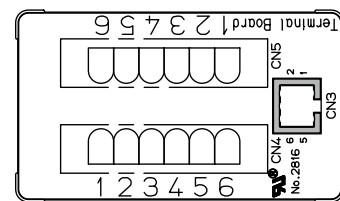

Figure 2 Terminal Board

Pin No	Function
1	+24V
2	0V
3	Alarm contact-Normal Open
4	Alarm contact-Common
5	Trouble contact-Normal Close
6	Trouble contact-Common